

E2M.01 ANCHORING CONCRETE GROUND/CEILING

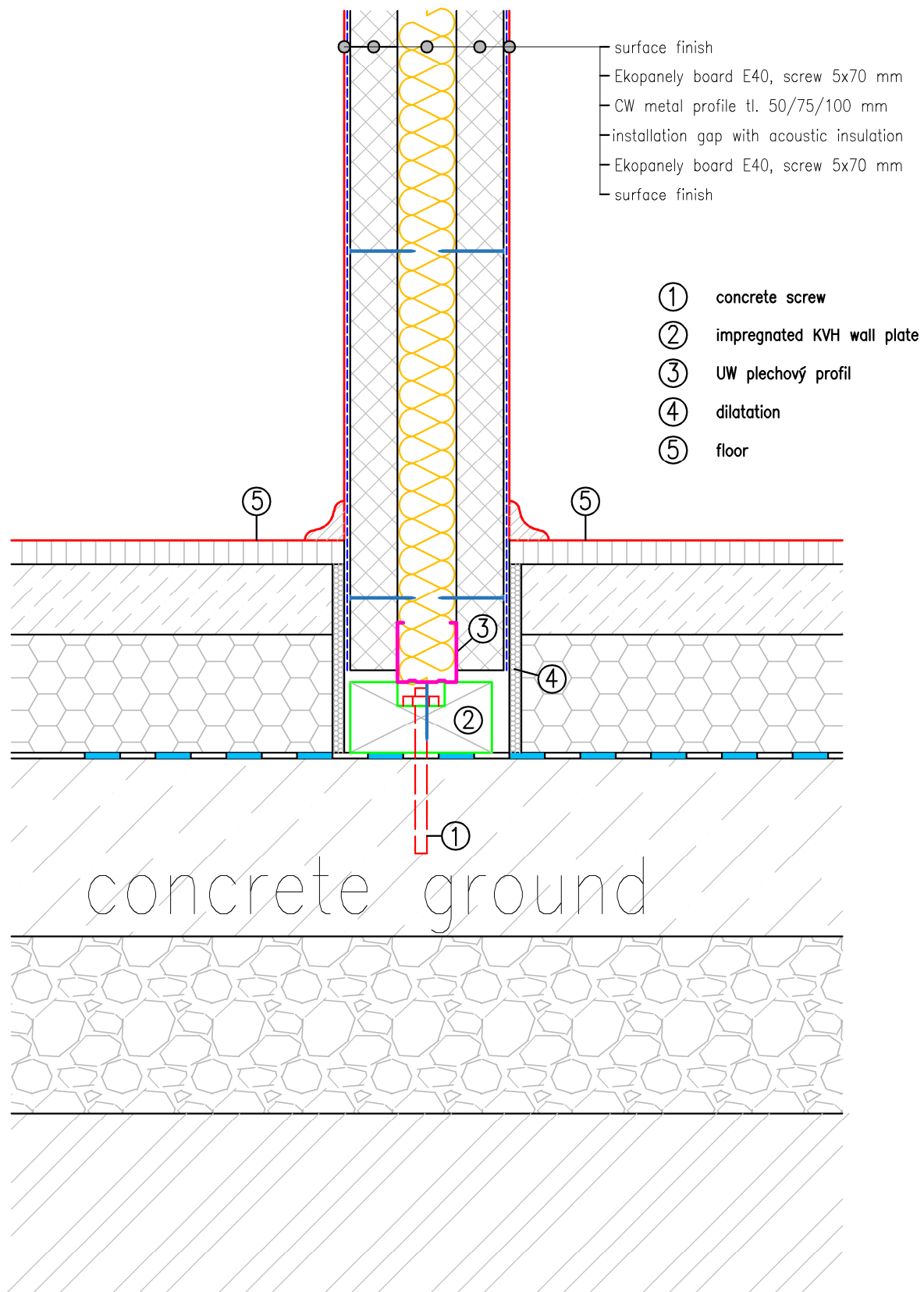

Notice!

The given illustration represents only a design proposal. Applicability must be verified by the processor/customer. The processor / customer assumes full responsibility for the selected and used application.

E2M.02 ANCHORING WOODEN STRUCTURE AND SLANTED CEILING

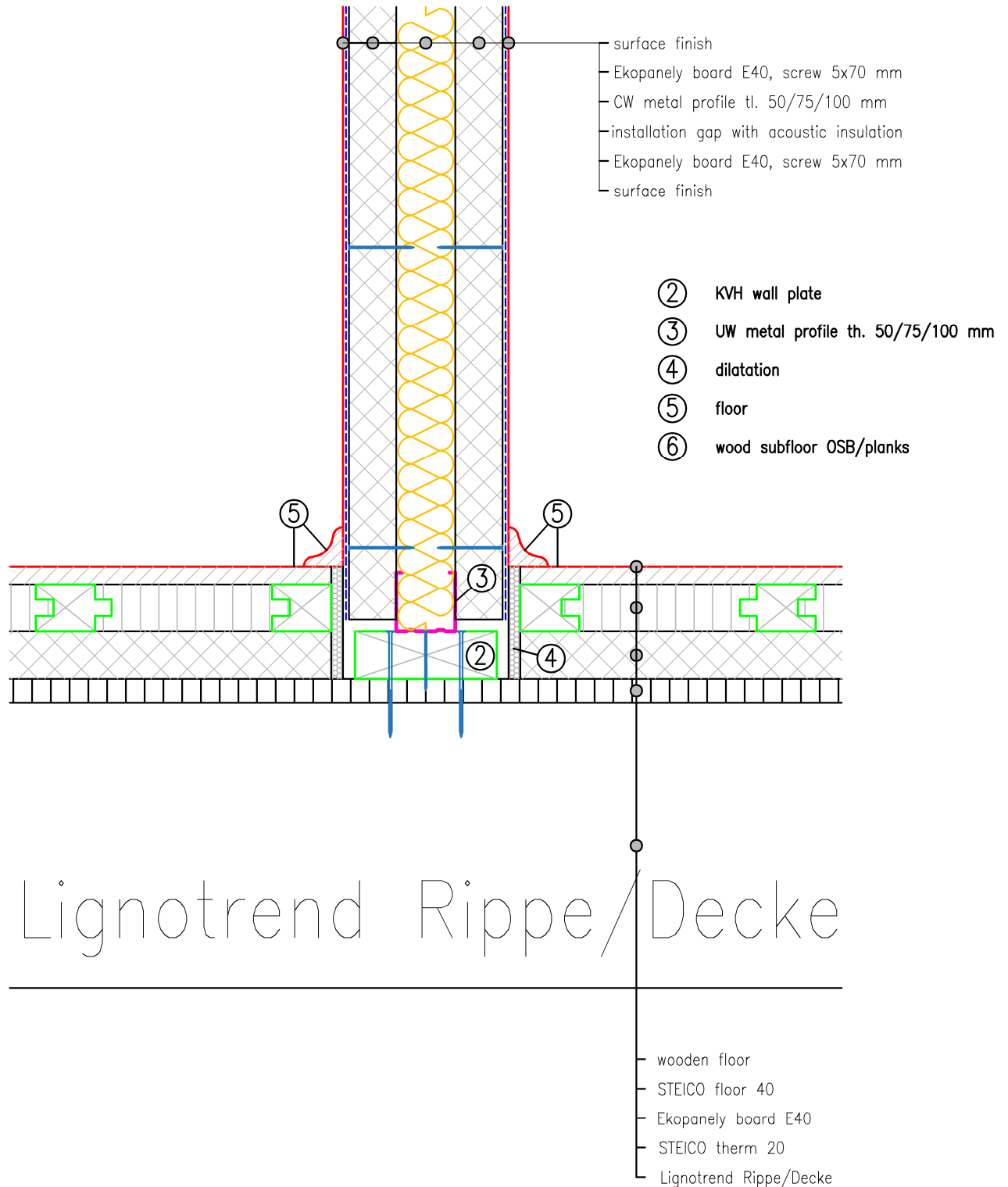

Lignotrend Rippe/Decke

Notice!

The given illustration represents only a design proposal. Applicability must be verified by the processor/customer. The processor / customer assumes full responsibility for the selected and used application.

E2M.03 ANCHORING FLAT OR SLANTED CEILING/ROOF

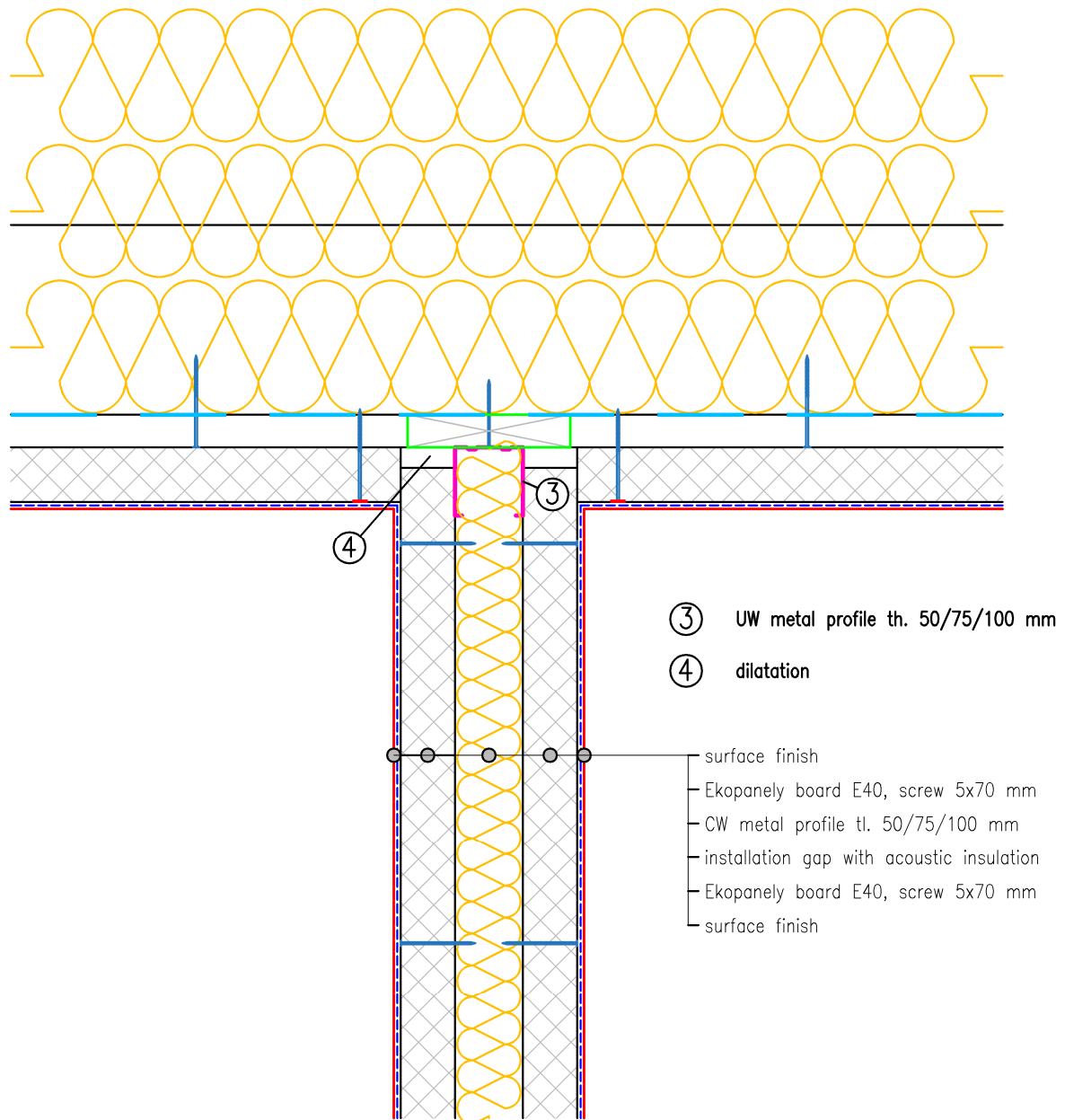

Notice!

The given illustration represents only a design proposal. Applicability must be verified by the processor/customer. The processor / customer assumes full responsibility for the selected and used application.

E2M.04 ANCHORING WOODEN STRUCTURE AND SLANTED CEILING

EXTERIOR

- roofing
- STEICO universal
- STEICO joist/ STEICO ZELL 0,044 W/(mK)
- vapor barrier whit a variable diffusion
- wooden plank for anchoring Ekopanely board th. 24 mm
- Ekopanely board E40, screw 5x70 mm
- surface finish

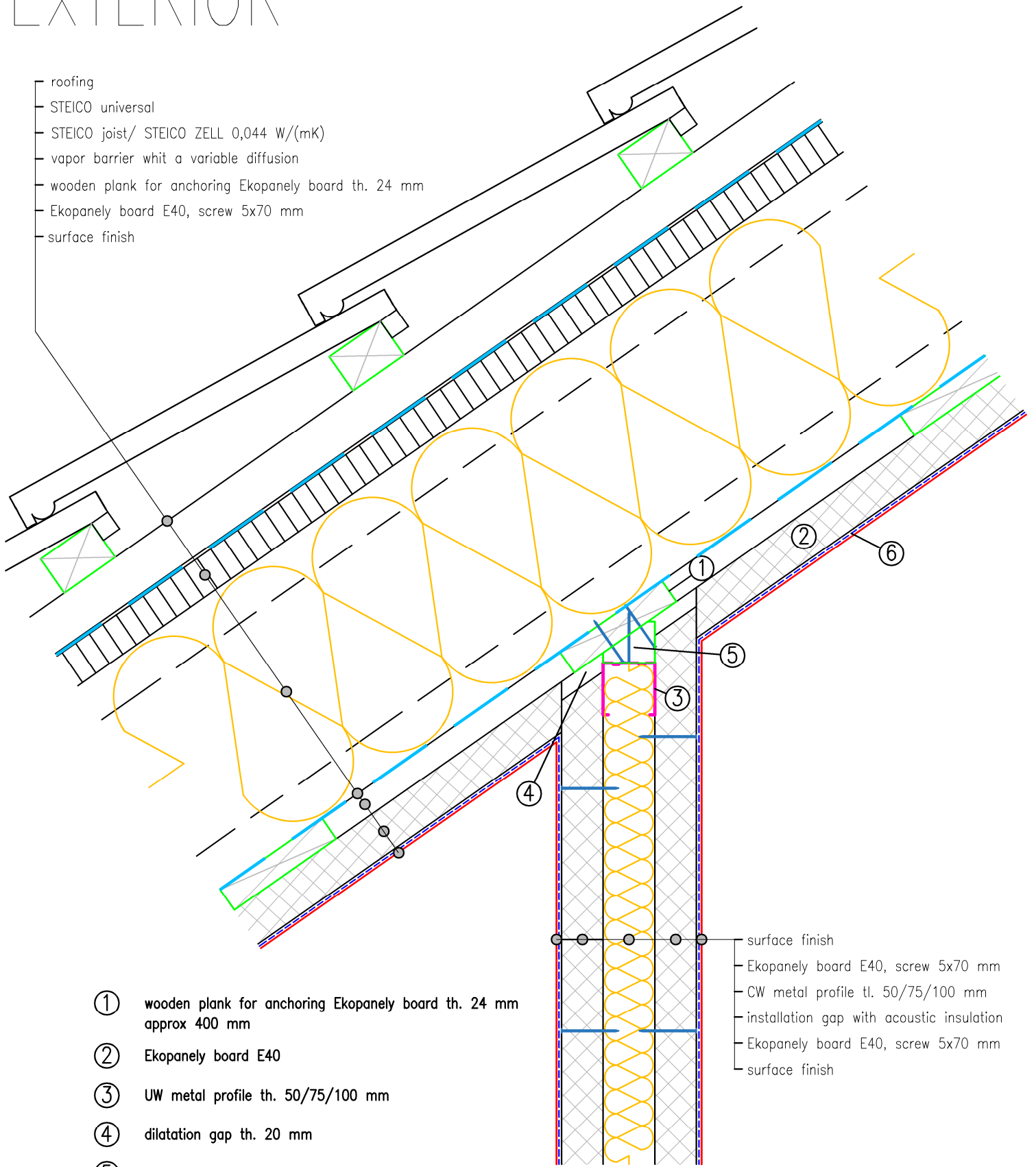

- ① wooden plank for anchoring Ekopanely board th. 24 mm approx 400 mm
- ② Ekopanely board E40
- ③ UW metal profile th. 50/75/100 mm
- ④ dilatation gap th. 20 mm
- ⑤ leveling batten
- ⑥ surface finish

- surface finish
- Ekopanely board E40, screw 5x70 mm
- CW metal profile tl. 50/75/100 mm
- installation gap with acoustic insulation
- Ekopanely board E40, screw 5x70 mm
- surface finish

INTERIOR

Notice!

The given illustration represents only a design proposal. Applicability must be verified by the processor/customer. The processor / customer assumes full responsibility for the selected and used application.

E2M.06 CONNECTION E2M PARTITION AND DIFFERENT EXTERIOR WALL

EXTERIOR

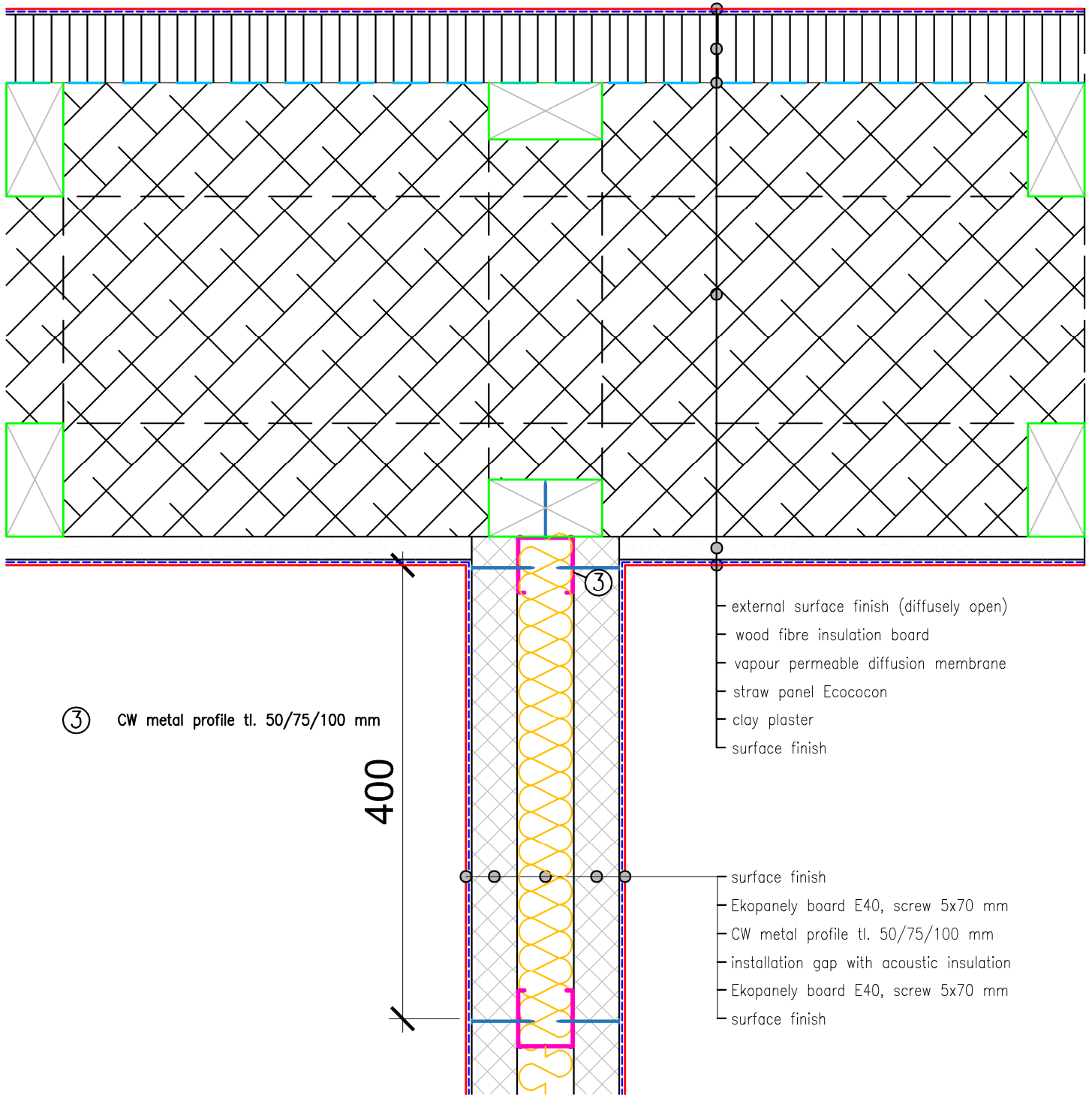

INTERIOR

Notice!

The given illustration represents only a design proposal. Applicability must be verified by the processor/customer. The processor / customer assumes full responsibility for the selected and used application.

E2M.08 CONNECTION E2M PARTITION AND E2M PARTITION

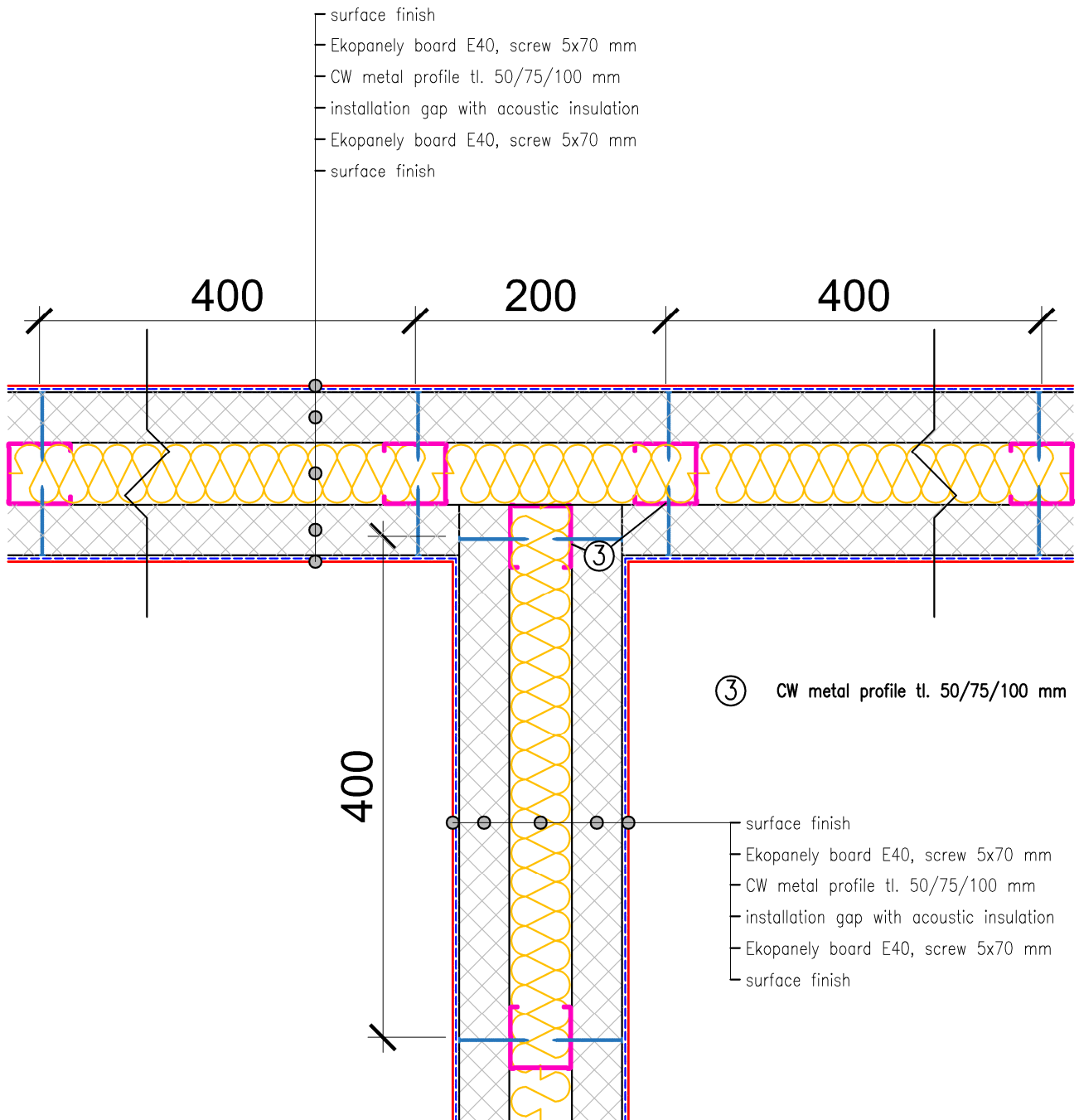

Notice!

The given illustration represents only a design proposal. Applicability must be verified by the processor/customer. The processor / customer assumes full responsibility for the selected and used application.